

## Composition of Probe

- TP400 cable probe consist of three pieces:
- 1) TP400 trigger probe unit(with integrating interface);
  - 2) Two four-core, oil proof shielded cable, one of them is a spiral cable with aviation plugs at both ends. The total length of the two cables is 8 meters;
  - 3) Stylus(standard model: M4-P50-RB6-S36).

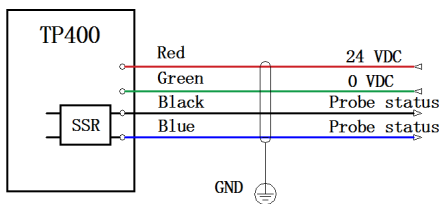
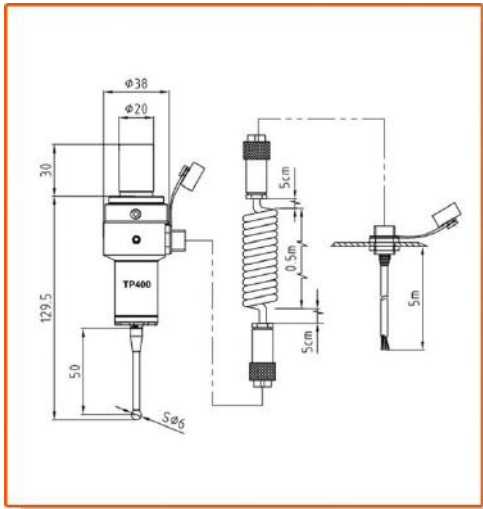

## Notes for purchase

- ◆ As for special stylus, check whether the standard stylus equipped with the TP400 probe can meet the requirements and whether it is necessary to order special stylus;
- ◆ About sealing protection of the connectors for stylus and probe: for TP300 probe applied in CNC lathe, it is recommended that the customer give protecting instruction to use metal cover + rubber sealing cover when ordering the probe.

## Technical Parameters for probe and interface

- ◆ Stylus sensing direction:  $\pm X, \pm Y, +Z$ ;
- ◆ Stylus sensing over-travel:  $X-Y \pm 15^\circ, Z +5 \text{ mm}$ ;
- ◆ The trigger force in Z direction: 1000 g;
- ◆ Trigger force in X-Y surface ( standard stylus ) : 65-130g;
- ◆ Unidirectional repeatability ( $2\sigma$ ) :  $\leq 2 \mu\text{m}$ ;
- ◆ Input voltage is  $24 \pm 10\% \text{ V DC}$  and output load current is 50 mA.
- ◆ Seal grade: IP68.

## Technical Characteristics

- ◆ The signal interface of probe is integrated inside the probe, and the trigger signal is transmitted by cable;
- ◆ By changing the power supply's polarity at the probe interface, the logic state of the output signal can be reversed;
- ◆ The stylus connector of the probe is protected by double layers of rubber seal.
- ◆ The probe uses two pieces of cable to transmit signals, one of spiral cable has aviation plugs at both ends , which can be quickly installed and discounted, providing convenience for the application of the probe in different equipments.

## Basic configuration

- ◆ The standard: M4-P50-RB6-S36;
- ◆ The cable: 4 cores' shielded, oil - proof sporting cable, length:6m.

## Application

- ◆ Setting work-piece coordinate system and machining zero points automatically before processing;
- ◆ Detect and control the key dimensions, position coordinates and their precision automatically between two processes;
- ◆ Detect precision of the key dimensions, shapes, position after processing.
- ◆ Applicable equipments: various specifications of CNC grinding machines, CNC lathes and specially measuring devices.